

Merits

P326A series *Service Manual*

Index

<i>Index</i>	1
1. Introduction	1
2. Service guide	1
2.1. How to replace or repair the seat assembly	1
2.1.1. To replace the seat body.....	1
2.1.2. To replace the seat base plate assembly	2
2.1.3. To replace the seat post	2
2.1.4. To replace the left/right armrest	3
2.2. How to replace or repair the body assembly	4
2.2.1. To replace the main shroud	4
2.2.2. To replace the fender	5
2.2.3. To replace the battery pack	5
2.2.4. To replace the footplate assembly	5
2.2.5. To replace the anti-tipper arm assembly - front	6
2.2.6. To replace the anti-tipper arm assembly - rear.....	8
2.2.7. To replace the caster wheel assembly	10
2.2.8. To replace the driver wheel assembly	11
2.2.9. To replace the main frame.....	13

The numbers shown in this service manual is just for reference. The part numbers should be in accordance with current exploded drawing.

1. Introduction

The purpose of this manual is to provide dealers and/or distributors with the product information and instructions that are required for servicing the P326A powerchair.

2. Service guide

The P326A powerchair consists of three main parts:

- Seat assembly
- Body assembly
- Electrical system (Please refer to P3 series Shark or VR2 service manual)

2.1. How to replace or repair the seat assembly

The seat assembly includes the seat body, the seat base plate, seat post and the left/right armrest.

2.1.1. To replace the seat body

◆ When should you replace the seat body?

◇ If the seat body is worn out.

◇ If the seat body is pierced or scratched by something.

If the powerchair crashed cause the seat body out of shape.

◆ How to replace the seat body?

◇ Please proceeding steps as follows if it is broken.

a. Pull the swivel lever (4.44) under the seat up to unlock it and rotate the seat a little bit to the position where you can feel the seat rotate freely. Pull the seat upward.

b. Use hex tools to loosen four pieces hex fixed bolt (4.50) on seat base plate assembly and remove the seat body from the seat base plate assembly if it is broken.

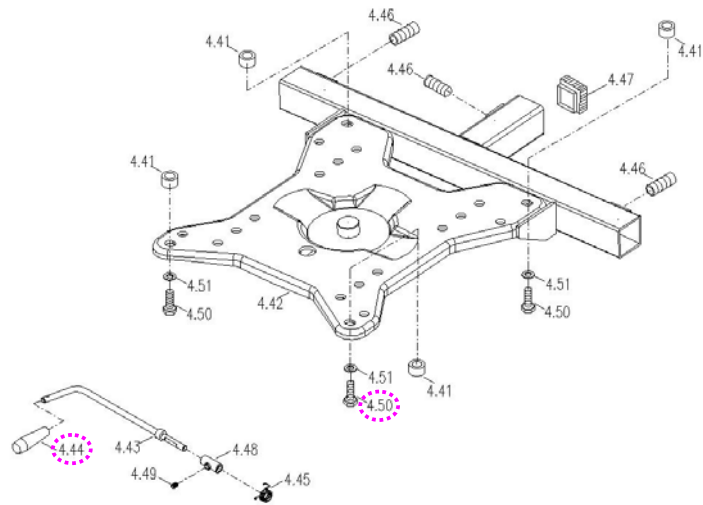

2.1.2. To replace the seat base plate assembly

- ◆ When should you replace the seat base plate assembly?
 - ◇ If the seat base plate is deformation.
 - ◇ If the seat base plate out of shape due to an accident.
- ◆ How to replace the seat base plate assembly?
 - ◇ Please proceeding steps as follows if it has to replace.

Follow preceding step of 2.1.1. You can remove seat base plate assembly too if it is worn out or deformed.

2.1.3. To replace the seat post

- ◆ When should you replace the seat post?
 - ◇ If the seat post is deformation.
 - ◇ If the seat post out of shape due to an accident.
- ◆ How to replace the seat post?
 - ◇ Please proceeding steps as follows if it has to replace.

To replace the seat post use two wrenches to loosen the nut (4.04) and screw (4.02) if it is worn out or deformed.

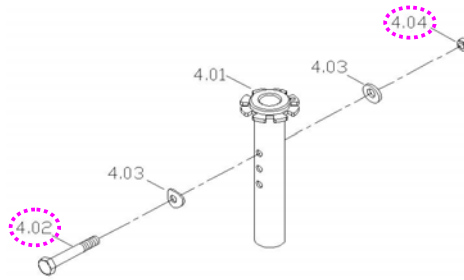

2.1.4. To replace the left/right armrest

- ◆ When should you replace the armrest?
 - ◇ If the armrest is worn out.
 - ◇ If the armrest is pierced or scratched by something.
 - If the powerchair crashed cause the armrest out of shape.
- ◆ How to replace the armrest?
 - ◇ Please proceeding steps as follows if it has to replace.

Use hex tools to loosen bolt (4.35) under armrest to disassemble armrest from armrest support plate. If the armrest is broken, then replace it.

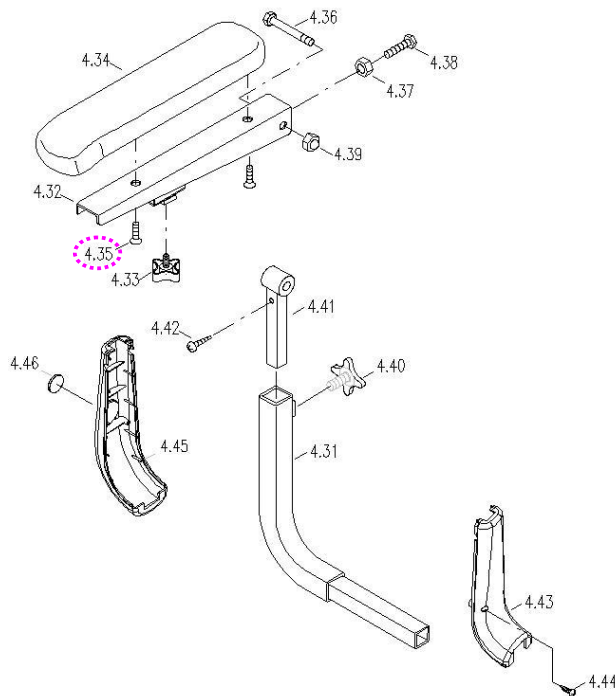

Note: The arm tube protective shrouds (4.43 and 4.45) are option parts for powerchair.

2.2. How to replace or repair the body assembly

The Body Assembly includes main shroud, fender, battery pack, footplate assembly, anti- tipper arm assembly - front, anti- tipper arm assembly - rear, caster wheel assembly, rear wheel assembly and the frame.

2.2.1. To replace the main shroud

- ◆ When should you replace the main shroud?
 - ◇ If your powerchair can not avoid knocked or bumped cause the shroud broken.
- ◆ How to replace the main shroud?
 - ◇ Check for deformations or cracks on the main shroud. Please proceeding steps as follows if it has to replace.
 - a. Turn and pull out the four plastic fasten bolts (1.53).
 - b. Simply lift the main shroud straight up.
 - c. Remove four o-rings (1.54) and replace the main shroud if it broken.

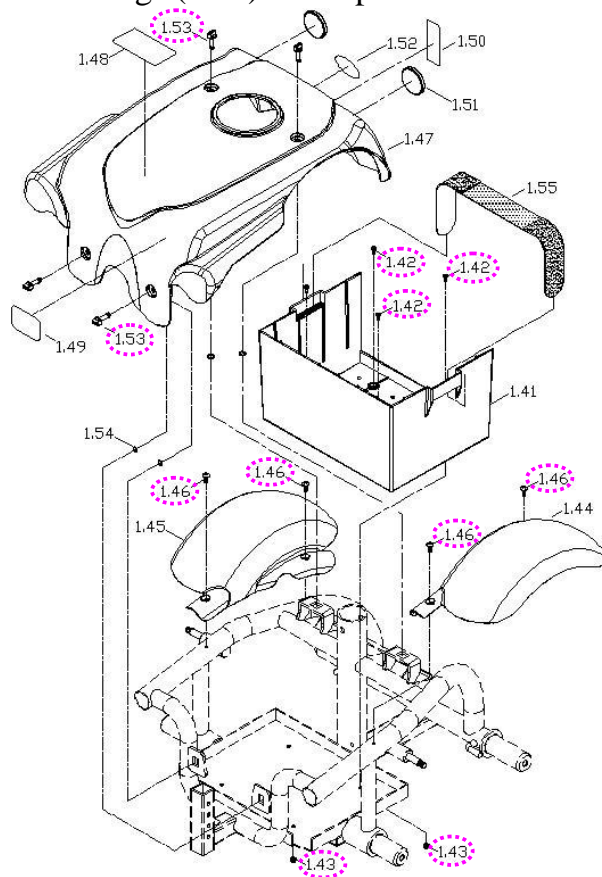

2.2.2. To replace the fender

- ◆ When should you replace the fender?
 - ◇ If your powerchair can not avoid knocked or bumped cause the fender broken.
- ◆ How to replace the fender?
 - ◇ Check for deformations or cracks on the fender. Please proceeding steps as follows if it has to replace.
 - a. Following the step 2.2.1. You can remove main shroud first.
 - b. Use screwdriver to loosen two screws (1.42) to replace the fender if it broken. (See page 4)

2.2.3. To replace the battery pack

- ◆ When should you replace the battery pack?
 - ◇ If your powerchair can not avoid knocked or bumped cause the battery pack broken.
- ◆ How to replace the battery pack?
 - ◇ Check for deformations or cracks on the battery pack. Please proceeding steps as follows if it has to replace.
 - a. Remove the main shroud first (See page 4).
 - b. Use wrench to hold four screws (1.43) and use screw driver to loosen four screws (1.42) to replace the battery pack if it broken. (See page 4)

2.2.4. To replace the footplate assembly

- ◆ When should you replace the footplate assembly?
 - ◇ If the footplate is deformation.
 - ◇ If the footplate out of shape due to an accident.

◆ How to replace the footplate assembly?

◇ Please proceeding steps as follows if it has to replace.

Replace the footplate assembly if it is worn out or deformed. Hold the two screws (8.09) and loosen the two nuts (8.11) and then replace the footplate assembly.

Hold the screw (8.05) and loosen the nut (8.06) then remove the footplate. If the footplate is worn out, then replace it.

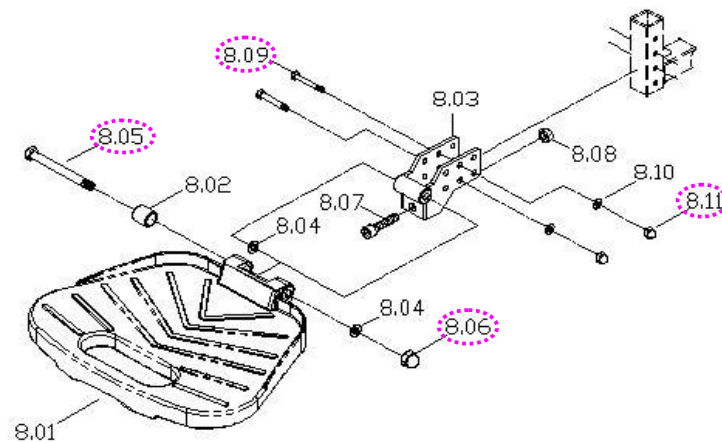

2.2.5. To replace the anti-tipper arm assembly - front

◆ When should you replace the anti-tipper arm assembly – front?

◇ If the anti-tipper arm assembly - front is worn out.

◇ If the anti-tipper arm tube - front (1.11) is deformed due to an accident. (see page 8)

◇ If your powerchair can not avoid knocked or bumped cause the PU wheel (7.04) broken. (see page 8)

◆ How to replace the anti-tipper arm assembly - front?

◇ Please proceeding steps as follows if it has to replace.

a. Please use hex tools to loosen the screw (1.21) and remove the washer. (see page 8)

b. Use hex tools to loosen the screw (1.17) and use wrench tool to

loosen the nut (1.19). (see page 8)

c. If the anti-tipper arm assembly - front is worn out or deformed.

◆ How to replace the anti-tipper arm - front?

◇ Please proceeding steps as follows if it has to replace.

a. Following the step above.

b. Remove the end cap (1.15). (see next page)

c. Use socket wrench to loosen the nut (1.14) then you can replace it. (see next page)

◆ How to replace the PU wheel?

◇ Please proceeding steps as follows if it has to replace.

a. Hold the screw (7.06) and loosen the nut (7.07) and then remove the PU wheel. (See next page)

b. If the PU wheel (7.04) is worn out, then replace it.

◆ How to replace the front absorber?

◇ Please proceeding steps as follows if it has to replace.

a. Remove the anti-tipper arm assembly - front first.

b. Use wrench tool to loosen the nut (1.08). (see page 14)

c. If the absorber (1.06) is worn out, then replace it. (see page 14)

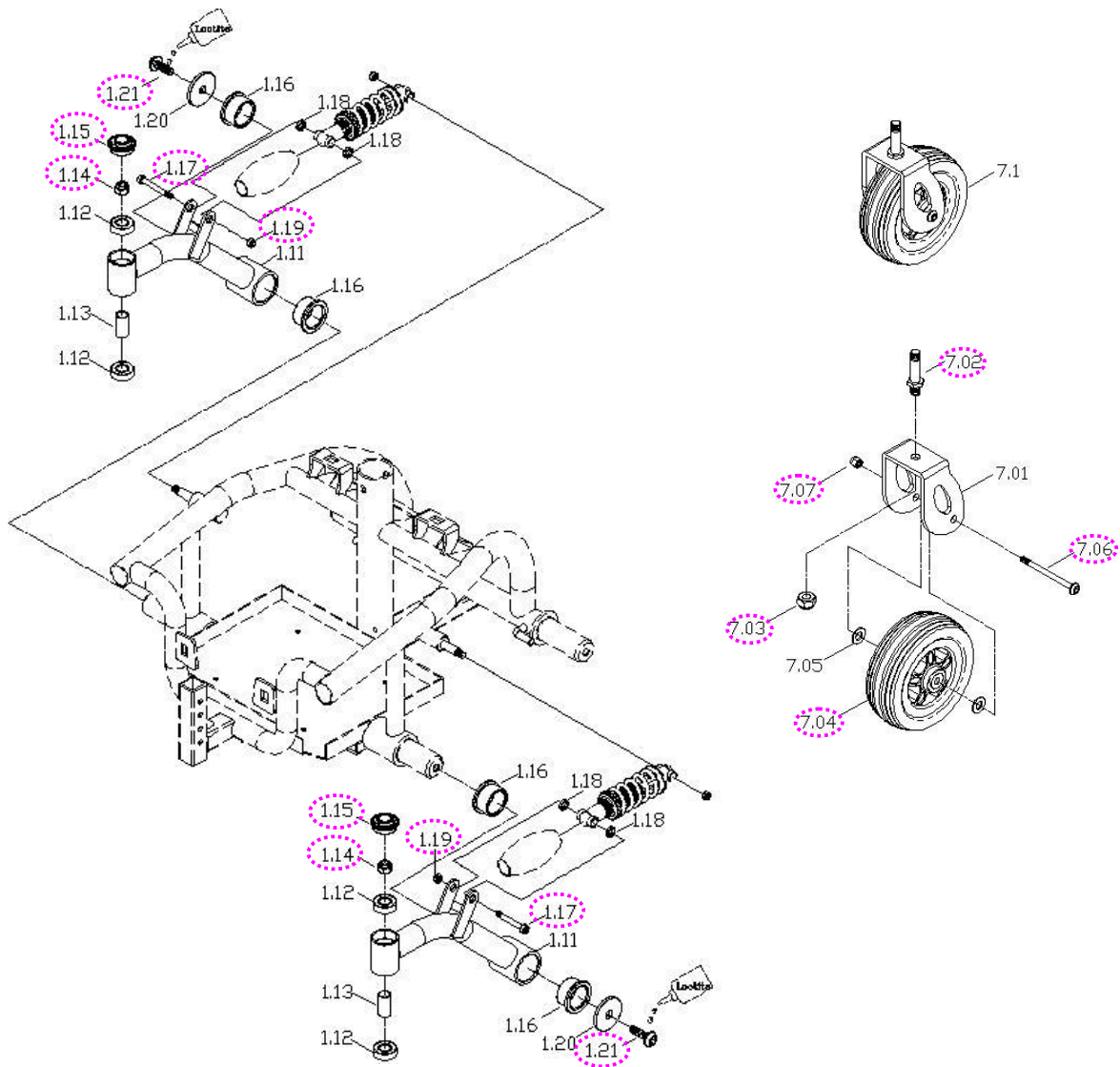

2.2.6. To replace the anti-tipper arm assembly - rear

- ◆ When should you replace the anti-tipper arm assembly - rear?
 - ◇ If the anti-tipper arm assembly - rear is worn out.
 - ◇ If the anti-tipper arm tube (1.25) is deformed due to an accident. (see page 10)
 - ◇ If your powerchair cannot avoid being knocked or bumped because the PU wheel (7.04) is broken. (see page 8)
- ◆ How to replace the anti-tipper arm assembly - rear?
 - ◇ Please use hex tools to loosen the screw (1.39) and remove the

washer if the anti-tipper arm assembly is worn out or deformed.
(see page 10)

◆ How to replace the anti-tipper arm tube - rear?

◇ Please proceeding steps as follows if it has to replace.

- a. Following the step above.
- b. Use hex tools to loosen the screw (1.36). (see next page)
- c. Remove the end cap (1.29). (see next page)
- d. Use socket wrench to loosen the nut (1.28) then you can remove the PU wheel assembly. (see next page)
- e. Use wrench to loosen the nut (1.31) then you can replace the anti-tipper arm tube - rear. (see next page)

◆ How to replace the PU wheel?

◇ Please proceeding steps as follows if it has to replace.

- a. Hold the screw (7.06) and loosen the nut (7.07) and then remove the PU wheel. (See page 8)
- b. If the PU wheel (7.04) is worn out, then replace it. (See page 8)

◆ How to replace the rear absorber?

◇ Please proceeding steps as follows if it has to replace.

- a. Use the hex tools hold the screw (1.36) and use wrench to loosen the screw (1.37). (see next page)
- b. Use the wrench to loosen the nut (1.31), then you can remove the absorber (1.30) if it is worn out. (see next page)

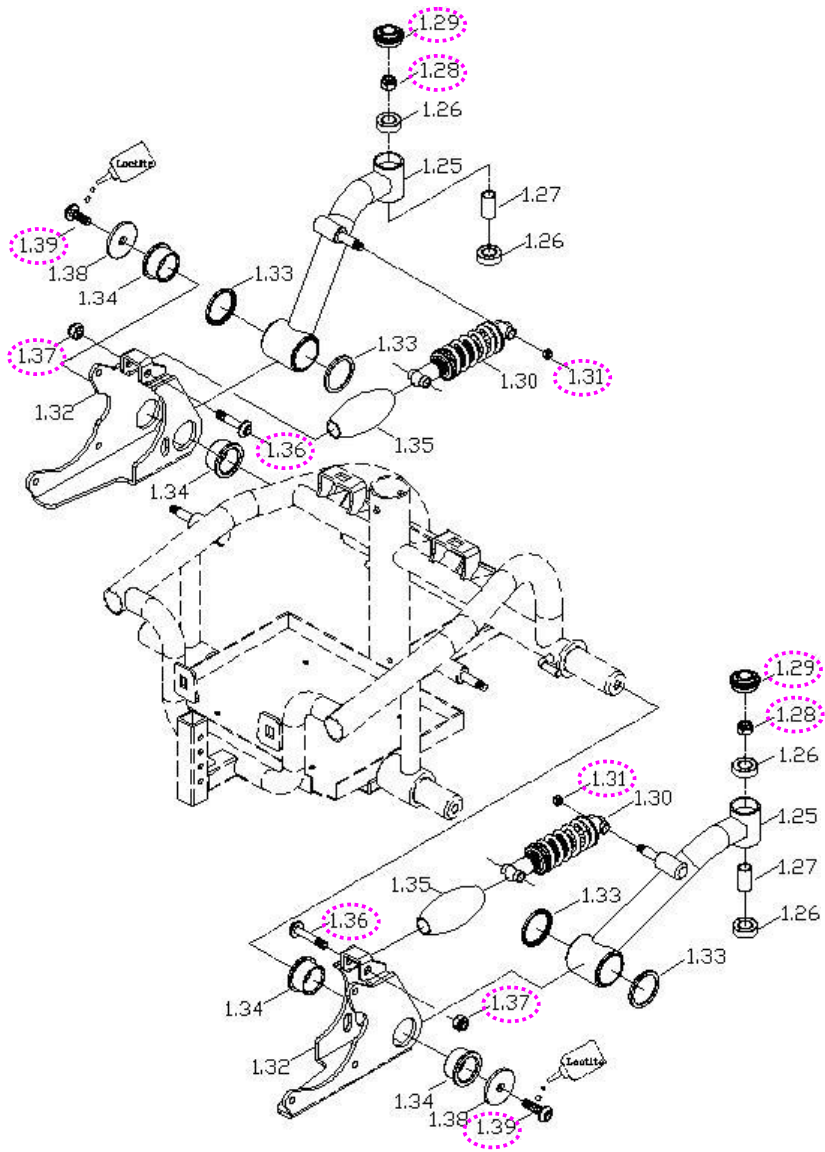

2.2.7. To replace the castor wheel assembly

- ◆ When should you replace the castor wheel assembly?
 - ◇ If the castor wheel assembly is worn out.
 - ◇ If the stud (7.02) of castor wheel assembly is broken.(See page 8)
 - ◇ If the castor wheel assembly is deformed due to an accident.

- ◆ How to replace the caster wheel assembly?
- ◇ Please proceeding steps as follows if it has to replace.

The caster wheel assembly is composed of a PU wheel and fork.

Replace the caster wheel assembly by the following steps if, after inspection, the assembly is found to be deformed.

- a. Remove the seat assembly.
- b. Use screw driver to remove the end cap (1.15 and 1.29, see page 8 and page 10). Fix the caster wheel in place. Hold the stub (7.02) and loosen the nut (1.14 and 1.28, see page 8 and page 10) and then you can remove the caster wheel assembly. (See page 8)

Replace the PU wheel by the following steps if it is worn out or deformed.

- a. Hold the screw (7.06) and loosen the nut (7.07) and then remove the PU wheel. (See page 8)
- b. If the PU wheel is worn out, then replace it.

2.2.8. To replace the driver wheel assembly

- ◆ When should you replace the driver wheel assembly?
- ◇ If the driver wheel assembly is worn out.
- ◇ If the driver wheel assembly is deformed due to an accident.

- ◆ How to replace the driver wheel assembly?
- ◇ Please proceeding steps as follows if it has to replace.

Use socket wrench to loosen the nut (5.04) and washer (5.03) to replace the driver wheel assembly if it is worn out or deformed.

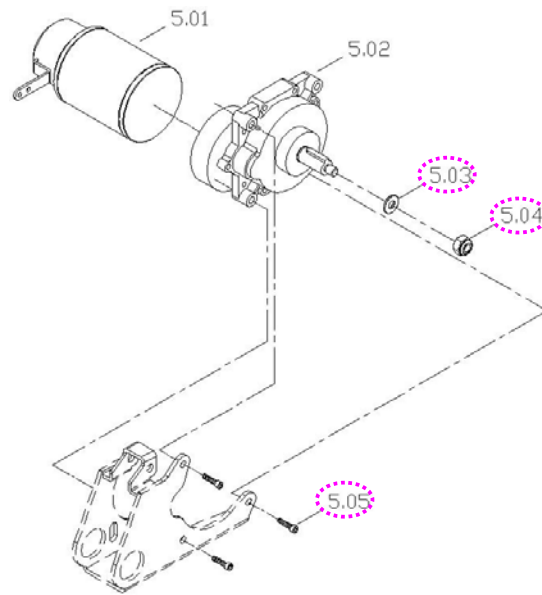

Replace the driver wheel by the following steps if it is worn out or deformed.

- a. Follow preceding step above.
- b. If the PU tire is worn out. Hold the screw (5.33) in place and use socket wrench to loosen the nut (5.34) and replace it.

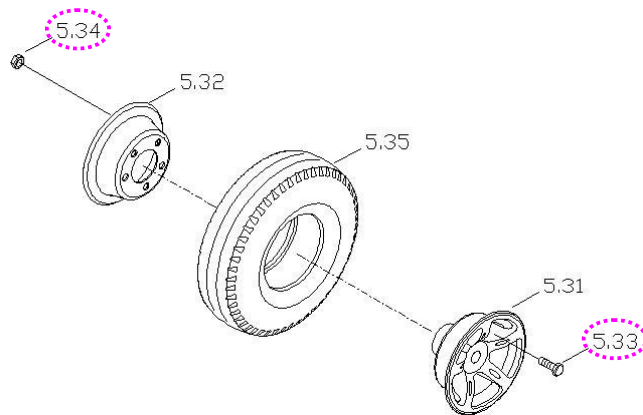

2.2.9. To replace the main frame

- ◆ When should you replace the frame?
 - ◇ If the main frame is deformation.
 - ◇ If your powerchair can not avoid knocked or bumped cause the frame deform.
 - ◇ If the main frame is deformed due to an accident.

- ◆ How to replace the main frame?
 - ◇ Please proceeding steps as follows if it has to replace.

Check the whole body assembly by the following steps if there is noise or sticking motion during operation of the powerchair.

- a. Remove the seat assembly, the main shroud, the fender, the battery pack, the footplate assembly, the anti-tipper arm assembly, the caster wheel assembly and drive wheel assembly by step 2.1, 2.2.1 until 2.2.8 previously.
- b. Use hex tools to loosen three pieces the screw (5.05) to remove motor and gearbox assembly. (See page 12)
- c. Hold the screw (1.04) and loosen the nut (1.03) to remove controller. (See next page)
- d. Use screw driver to remove four pieces snap in (1.05) and end cap (1.09). (See next page)
- e. Use wrench to loosen the nut (1.08) then remove the absorber. (See next page)
- f. Check for deformations or cracks on the frame and replace the main frame should they exist.

